

SHT



The Aston Seals SHT is the optimal solution for industrial hydraulic applications. It can be used in the same housing normally destined to PTFE seal of which has similar technical and dimensional characteristics but, compared to it, better sealing capabilities, greater ease of installation and a lower cost.

The SHT, composed of a high resistance polymer element on the dynamic side and an O-Ring as energizing component on the static side, can be used:

- individually
- in tandem: preferable solution in the presence of rapid and high pressure variations.
- Good sealing performance

- Low cost compared to the corresponding PTFE seal
- Easy installation
- Low friction and no tendency of stick-slip
- Returns to the size immediately after assembly
- Simple groove design and space-saving construction
- Excellent wear-resistance
- High resistance against extrusion
- Extended service life
- Good temperature resistance

MATERIAL

	① Type	Thermoplastic polyester resin
	Designation	SEALITE 55
	Hardness	55 °ShD
	② Type	Nitril Rubber NBR
	Designation	RUBSEAL 70
	Hardness	70 °ShA

FIELD OF APPLICATION

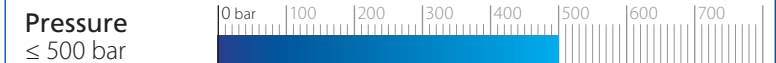

Fluids
Hydraulic oils (mineral oil based)
For other fluids contact our technical department

SURFACE ROUGHNESS

Dynamic surface	Ra ≤ 0.3 μm	Rt ≤ 2.5 μm
Static surface	Ra ≤ 1.6 μm	Rt ≤ 6.3 μm

GAP DIMENSION "g"

The largest gap dimension appearing in operation on the non-pressurised side:

L	100 bar	200 bar	300 bar	400 bar
2.2	0.70	0.45	0.35	0.30
3.2	0.80	0.50	0.40	0.30
4.2	0.80	0.50	0.40	0.35
6.3	0.90	0.55	0.45	0.35
8.1	1.10	0.70	0.50	0.40

$$> 400 \text{ bar} \Rightarrow g_{\max} = H8/f8$$

To avoid damaging the sealing lips during installation, housing must have rounded chamfers. Sharp edges and burrs within the installation area of the seal must be removed.

The above data are maximum values, they may be maintained for short periods and can not be used at the same time simultaneously.

SHT

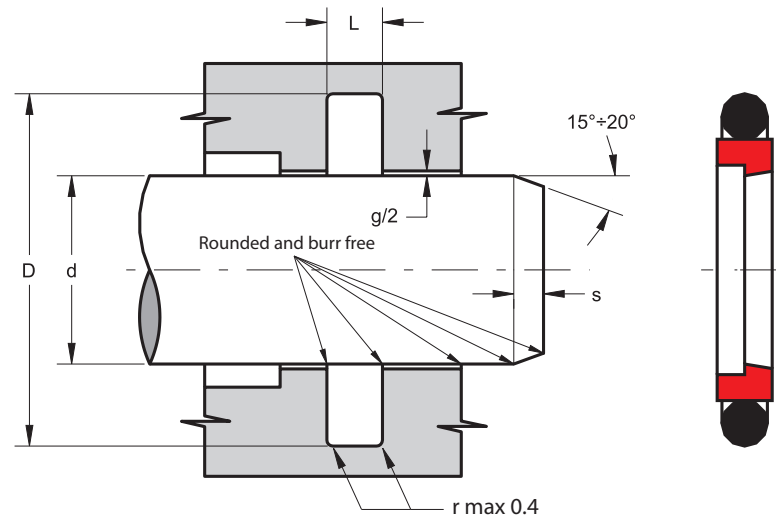

Part.	d ^{h9}	D ^{H10}	L ^{+0.2}	S	OR
SHT 10 14.9 2.2	10	14.9	2.2	2.0	013
SHT 14 18.9 2.2	14	18.9	2.2	2.0	016
SHT 16 20.9 2.2	16	20.9	2.2	2.0	017
SHT 18 22.9 2.2	18	22.9	2.2	2.0	018
SHT 20 27.3 3.2	20	27.3	3.2	2.5	118
SHT 20 30.7 4.2	20	30.7	4.2	3.5	214
SHT 22 32.7 4.2	22	32.7	4.2	3.5	215
SHT 24 34.7 4.2	24	34.7	4.2	3.5	216
SHT 25 32.3 3.2	25	32.3	3.2	2.5	122
SHT 25 35.7 4.2	25	35.7	4.2	3.5	217
SHT 30 37.3 3.2	30	37.3	3.2	2.5	125
SHT 30 40.7 4.2	30	40.7	4.2	3.5	220
SHT 32 39.3 3.2	32	39.3	3.2	2.5	126
SHT 32 42.7 4.2	32	42.7	4.2	3.5	221
SHT 35 45.7 4.2	35	45.7	4.2	3.5	222
SHT 36 46.7 4.2	36	46.7	4.2	3.5	223
SHT 40 50.7 4.2	40	50.7	4.2	3.5	224

Part.	d ^{h9}	D ^{H10}	L ^{+0.2}	S	OR
SHT 40 55.1 6.3	40	55.1	6.3	5.0	327
SHT 45 55.7 4.2	45	55.7	4.2	3.5	830
SHT 45 60.1 6.3	45	60.1	6.3	5.0	329
SHT 50 60.7 4.2	50	60.7	4.2	3.5	833
SHT 50 65.1 6.3	50	65.1	6.3	5.0	331
SHT 56 66.7 4.2	56	66.7	4.2	3.5	229
SHT 57 72.1 6.3	57	72.1	6.3	5.0	333
SHT 60 70.7 4.2	60	70.7	4.2	3.5	839
SHT 60 75.1 6.3	60	75.1	6.3	5.0	334
SHT 70 80.7 4.2	70	80.7	4.2	3.5	846
SHT 70 85.1 6.3	70	85.1	6.3	5.0	337
SHT 75 90.1 6.3	75	90.1	6.3	5.0	339
SHT 78 93.1 6.3	78	93.1	6.3	5.0	339
SHT 80 95.1 6.3	80	95.1	6.3	5.0	340
SHT 90 105.1 6.3	90	105.1	6.3	5.0	343
SHT 100 115.1 6.3	100	115.1	6.3	5.0	346
SHT 110 125.1 6.3	110	125.1	6.3	5.0	350